



Heckmann Building Products Inc.

1501 N. 31st Avenue

Melrose Park, IL 60160-2911

800-621-4140 or 708-865-2403 Fax: 708-865-2640

www.heckmannbuildingprods.com

SUBMITTAL SHEET: #183 SPLIT-BEND STRAP BOLT

MADE TO ORDER:

Thickness of Strap: 1/4", 3/16", 1/8", 11 gage, 12 gage, & 16 gage.

Diameter of Threaded Rod: 1/4", 3/8", 1/2".

Strap Width: 1-1/4" minimum recommended. Minimum width for 1/4" thick is 2" wide.

Length: Specify length of strap from end to i.d. of split bend, and Length of threaded rod extending beyond the strap. (Threaded rod is welded 1" onto the strap unless otherwise specified.)

Split Bend: Minimum 3/4" recommended (specify as i.d. dimension)

Available in Stainless Steel, Hotdip Galvanized After Fabrication, Electro Galvanized After Fabrication, or Plain Steel.

Nut and Washer are included unless otherwise specified.

Stainless Steel:

Sheet metal anchors and ties: ASTM A 167 AISI Type 304.

Plate and bent bar anchors: ASTM A 666 AISI Type 304.

Wire ties and anchors: ASTM A 580 AISI Type 304.

Hotdip Galvanized:

ASTM A 153 Class B-2: (1.50 oz/ ft²)(0.46kg/m²)

Mill Galvanized:

Sheet metal anchors and ties: ASTM A 653 G60

Wire: ASTM A 641 (0.1 oz/ ft².)

Plain Steel:

Sheet Metal anchors and ties: ASTM A 569, ASTM A 366.

Plates, bars, and shapes: ASTM A 123, ASTM A 36.

Wire: ASTM A 82, ASTM A 82-95a.

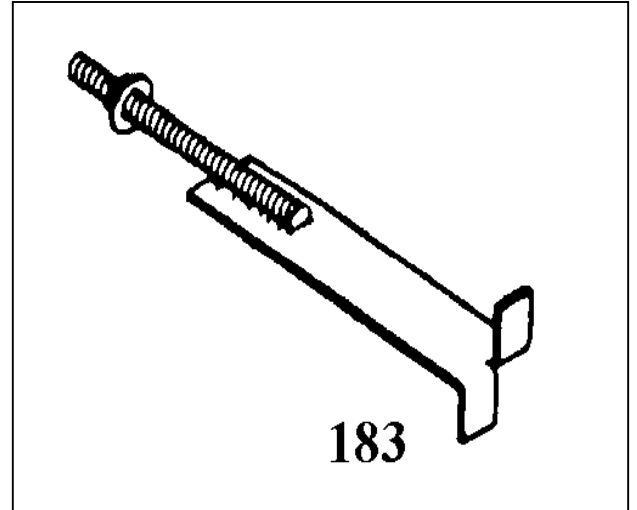

Approvals:

Comments: