



Heckmann Building Products Inc.

1501 N. 31st Avenue

Melrose Park, IL 60160-2911

800-621-4140 or 708-865-2403 Fax: 708-865-2640

www.heckmannbuildingprods.com

SUBMITTAL SHEET: #274 SCREW-ON SPLIT BEND ANCHOR

MADE TO ORDER

Thickness: 3/16", 1/8", 11 gage, 12 gage, & 16 gage.

Strap Width: 1-1/4" minimum recommended.
Minimum width for 1/4" thick is 2" wide.

Length: Specify length as the inside dimensions between the bends.

Bend with Hole: 1" minimum recommended.
You should consider the overall length of the anchor and the height of the split bend to make sure there is enough room for the installer to get the screw and tool in place without interference from the split bend. Hole should be minimum of 1/16" larger than your screw size. (3/8" screw will use a 7/16" diameter hole).

Split Bend: Minimum 3/4" recommended (specify as i.d. dimension)

Available in Stainless Steel, Hotdip Galvanized After Fabrication, Electro Galvanized After Fabrication, or Plain Steel. Stainless Steel recommended for any exterior stone application.

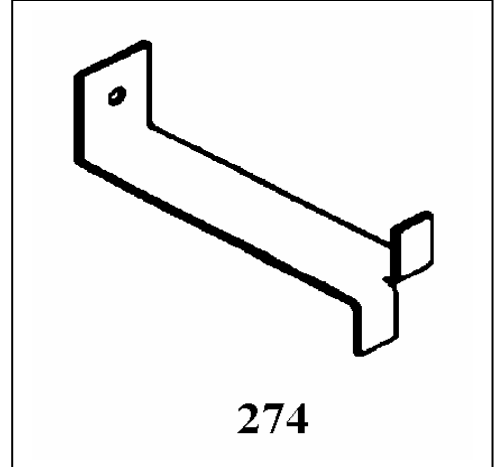
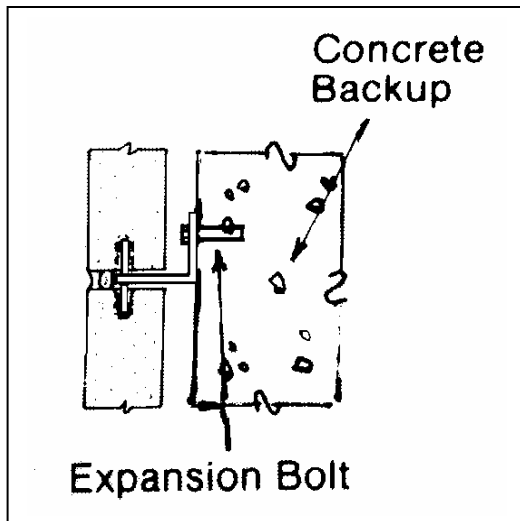

Stainless Steel:

Sheet metal anchors and ties: ASTM A 167 AISI Type 304.

Plate and bent bar anchors: ASTM A 666 AISI Type 304.

Wire ties and anchors: ASTM A 580 AISI Type 304.

Hotdip Galvanized:

ASTM A 153 Class B-2: (1.50 oz/ ft²).(0.46kg/m²)

Mill Galvanized:

Sheet metal anchors and ties: ASTM A 653 G60

Wire: ASTM A 641 (0.1 oz/ ft².)

Plain Steel:

Sheet Metal anchors and ties: ASTM A 569, ASTM A 366.

Plates, bars, and shapes: ASTM A 123, ASTM A 36.

Wire: ASTM A 82, ASTM A 82-95a.

Firewall Anchors:

Roller Strip Zinc Alloy 710.

(Firewall alloy 1/8" and 16 gage only)

Approvals:

Comments: