



Heckmann Building Products Inc.

1501 N. 31st Avenue

Melrose Park, IL 60160-2911

800-621-4140 or 708-865-2403 Fax: 708-865-2640

www.heckmannbuildingprods.com

SUBMITTAL SHEET: #276 PIN-TYPE SCREW-ON ANCHOR

MADE TO ORDER:

Thickness of Strap: 1/4", 3/16", 1/8", 11 gage, 12 gage, & 16 gage.

Diameter of Pin: 1/4", 3/8", 1/2", 5/8"

Strap Width: 1-1/4" minimum recommended.

Length: Specify length of strap to i.d. of bend and overall length of pin.

Bend Length: minimum 3/4" recommended (specify i.d. dimension)

Available in Stainless Steel, Hotdip Galvanized After Fabrication, Electro Galvanized After Fabrication, Mill galvanized (16ga - 11ga), or Plain Steel.

Bend Hole: Usually centered in bend. Hole should be 1/16" larger than screw/expansion anchor. (i.e. If using a 1/4" screw the hole diameter would be 5/16".)

Specify Location of Pin from center of pin to end. 1/2" minimum of steel between end of anchor and start of hole is recommended.

Pins are available loose or welded in place.

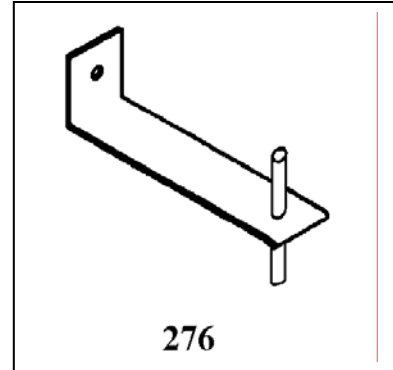
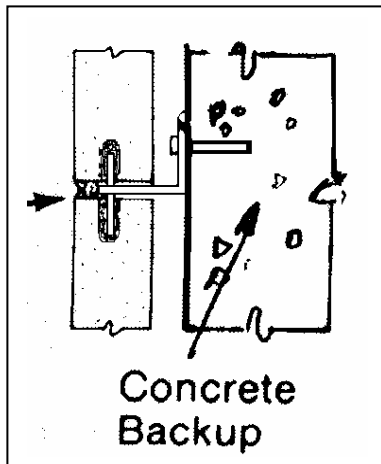

Stainless Steel:

Sheet metal anchors and ties: ASTM A 167 AISI Type 304.

Plate and bent bar anchors: ASTM A 666 AISI Type 304.

Wire ties and anchors: ASTM A 580 AISI Type 304.

Hotdip Galvanized:

ASTM A 153 Class B-2: (1.50 oz/ ft²).(0.46kg/m²)

Mill Galvanized:

Sheet metal anchors and ties: ASTM A 653 G60

Wire: ASTM A 641 (0.1 oz/ ft².)

Plain Steel:

Sheet Metal anchors and ties: ASTM A 569, ASTM A 366.

Plates, bars, and shapes: ASTM A 123, ASTM A 36.

Wire: ASTM A 82, ASTM A 82-95a.

Firewall Anchors:

Roller Strip Zinc Alloy 710.

(Firewall alloy 1/8" and 16 gage only)

Approvals:

Comments: