



Heckmann Building Products Inc.

1501 N. 31st Avenue

Melrose Park, IL 60160-2911

800-621-4140 or 708-865-2403 Fax: 708-865-2640

www.heckmannanchors.com

SUBMITTAL SHEET: #444 THREADED INSERTS

SIZE: See chart below for bolt sizes

APPLICATION: Threaded inserts are cast in concrete and offer a clean and unobtrusive appearance without protrusion beyond the face of the concrete. They permit anchor bolts and eye bolts to be removed and reinstalled as often as required. Material is Zamac Zinc Alloy only.

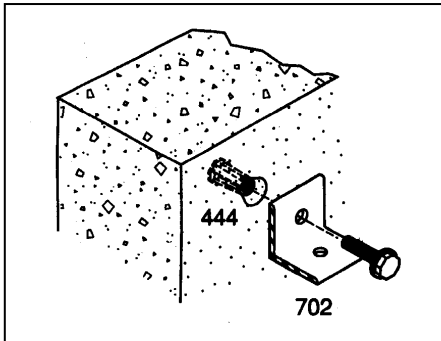

TEST CONDITIONS: The following chart is based on the average of many physical tests under proper conditions. (To obtain maximum load of insert machine bolt thread engagement must be at least 75% of the depth of the threaded hole. Use either bolts or threaded rods when attaching fixtures to the inserts.)

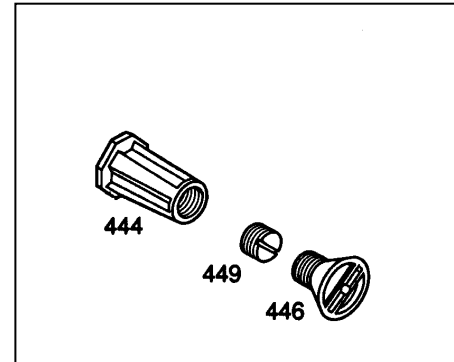

Approvals:

Comments:

Standard Number	Size	Bolt Size	Ultimate Load In Tension
P-15-T	1/4" x 1-1/2"	1/4-20	2,950
P-24-T	3/8" x 1"	3/8-16	5,712
P-25-T	3/8" x 1 3/8"	3/8-16	6,797
P-35-T	1/2" x 1 1/2"	1/2-13	8,945
P-36-T	1/2" x 2 7/8"	1/2-13	15,482
P-45-T	5/8" x 1 11/16"	5/8-11	11,800
P-46-T	5/8" x 2 7/8"	5/8-11	16,969
P-55-T	3/4" x 1 11/16"	3/4-10	6,207
P-56-T	3/4" x 2-7/8"	3/4-10	14,930

The strength of the concrete used in this test was over 5,000 psi.