



Heckmann Building Products Inc.

1501 N. 31st Avenue

Melrose Park, IL 60160-2911

800-621-4140 or 708-865-2403 Fax: 708-865-2640

www.heckmannanchors.com

SUBMITTAL SHEET: #569 U-TYPE POST BASE

Anchors post to concrete. 8" section below bearing plate is set in position before concrete is poured.

Stirrup: Height is 17-3/4" from inside of base: 9 3/4" above plate.

Plate: Width is between side of stirrup. Underside of plate is welded to stirrup.

Bolt Holes: Spaced 3" c.c. starting 1 1/2" from top. Holes are 1/16" larger than nominal diameter of bolt. Two bolts per unit.

Plate gage is 3/16"

Cat No.	Post Size	Plate Size	Stirrup
569-44	4 x 4	3 9/16 x 3 5/8	3/16 x 2
569-46	4 x 6	3 9/16 x 5 1/2	3/16 x 2
569-48	4 x 8	3 9/16 x 7 1/2	3/16 x 2
569-66	6 x 6	5 1/2 x 5 1/2	3/16 x 3
569-68	6 x 8	5 1/2 x 7 1/2	3/16 x 3
569-610	6 x 10	5 1/2 x 9 1/2	3/16 x 3
569-612	6 x 12	5 1/2 x 11 1/2	3/16 x 3
569-88	8 x 8	7 1/2 x 7 1/2	1/4 x 3

Available in Hotdip Galvanized After Fabrication or Stainless Steel

Special Sizes Available upon request.

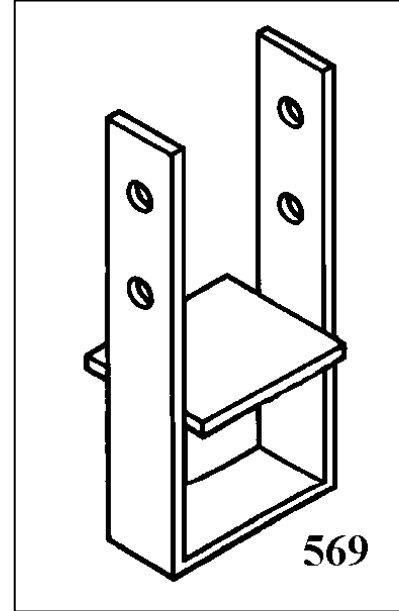

Stainless Steel:

Sheet metal anchors and ties: ASTM A 167 AISI Type 304.

Plate and bent bar anchors: ASTM A 666 AISI Type 304.

Wire ties and anchors: ASTM A 580 AISI Type 304.

Hotdip Galvanized:

ASTM A 153 Class B-2: (1.50 oz/ ft²).(0.46kg/m²)

Approvals:

Comments: